

Product data sheet

Characteristics

9070TF500D2

Transformer, Type TF, industrial control, 500 VA, 240/480 VAC primary / 24 VDC secondary, 1 phase, 50/60 Hz, 115 °C rise



Product availability: Non-Stock - Not normally stocked in distribution facility

Price*: 522.00 USD



Ordering and shipping details

Category	16207 - 9070 TF (NOT T) MTO
Discount Schedule	CP8
GTIN	00785901325192
Nbr. of units in pkg.	1
Package weight(Lbs)	1 Lb(US) (0.45 kg)
Returnability	No
Country of origin	US

Packing Units

Package 1 Height	6.00 In (15.240 cm)
Package 1 width	7.50 In (19.050 cm)
Package 1 Length	6.50 In (16.510 cm)

Offer Sustainability

Sustainable offer status	Green Premium product
California proposition 65	WARNING: This product can expose you to chemicals including: Phenyl glycidyl ether, which is known to the State of California to cause cancer and birth defects or other reproductive harm. For more information go to www.P65Warnings.ca.gov
REACH Regulation	REACH Declaration
EU RoHS Directive	Compliant EU RoHS Declaration
Mercury free	Yes
RoHS exemption information	Yes
China RoHS Regulation	China RoHS Declaration
Environmental Disclosure	Product Environmental Profile
PVC free	Yes

Contractual warranty

Warranty	18 months
----------	-----------

Approximate Dimensions

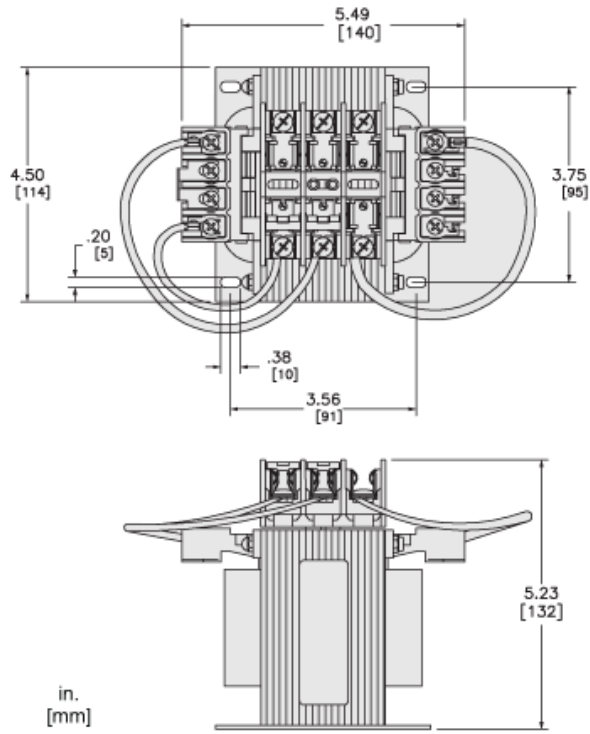

Product Life Status : Commercialised